

INCH-POUND

MIL-PRF-24613A(SH)

3 November 2007

SUPERSEDING

MIL-PRF-24613(SH)

21 March 1983

PERFORMANCE SPECIFICATION

DECK COVERING MATERIALS, INTERIOR, COSMETIC POLYMERIC

This specification is approved for use by the Naval Sea Systems Command, Department of the Navy and is available for use by all Departments and Agencies of the Department of Defense.

1. SCOPE

1.1 Scope. This specification establishes the performance requirements for cosmetic polymeric deck covering materials to be applied either directly over primed or unprimed, clean steel and aluminum interior deck surfaces, or over deck covering underlay materials conforming to MIL-PRF-3135, that provide a wear resistant, low maintenance deck surface.

1.2 Classification. Deck covering materials should be of the following types, classes, and grades, as specified (see 6.2):

1.2.1 Types.

- a. Type I – Epoxy resin based materials that require an initial seal coat.
- b. Type II – Polyurethane or polyurea based materials that require an initial seal coat.
- c. Type III – Epoxy resin based materials that do not require an initial seal coat.
- d. Type IV – Polyurethane or polyurea based materials that do not require an initial seal coat.
- e. Type V – Epoxy resin based materials that do not require periodic sanding or resealing at any time throughout an expected ten-year service life.
- f. Type VI – Polyurethane or polyurea based materials that do not require periodic sanding or resealing at any time throughout an expected ten-year service life.

1.2.2 Classes.

- a. Class 1 – Clear or colored resin base with colored quartz aggregate to provide the final cosmetic appearance.
- b. Class 2 – Colored resin base material with color flakes and a clear seal coat added to provide the final cosmetic appearance.
- c. Class 3 – Clear or colored resin base with marble chip aggregate to provide the final cosmetic appearance.
- d. Class 4 – Products consisting of two or more different colors of resin base materials that are mixed in order to provide a specific final cosmetic appearance.

1.2.3 Grades.

- a. Grade A – For use onboard submarines
- b. Grade B – For general shipboard use

Comments, suggestions, or questions on this document should be addressed to: Commander, Naval Sea Systems Command, ATTN: SEA 05M3, 1333 Isaac Hull Avenue, SE, Stop 5160, Washington Navy Yard DC 20376-5160 or emailed to CommandStandards@navy.mil, with the subject line "Document Comment". Since contact information can change, you may want to verify the currency of this address information using the ASSIST Online database at <http://assist.daps.dla.mil>.

MIL-PRF-24613A(SH)

2. APPLICABLE DOCUMENTS

2.1 General. The documents listed in this section are specified in sections 3, 4, or 5 of this specification. This section does not include documents cited in other sections of this specification or recommended for additional information or as examples. While every effort has been made to ensure the completeness of this list, document users are cautioned that they must meet all specified requirements of documents cited in sections 3, 4, or 5 of this specification, whether or not they are listed.

2.2 Government documents.

2.2.1 Specifications, standards, and handbooks. The following specifications, standards, and handbooks form a part of this document to the extent specified herein. Unless otherwise specified, the issues of these documents are those cited in the solicitation or contract.

FEDERAL STANDARD

FED-STD-141 - Paint, Varnish, Lacquer, and related materials: Methods of Inspection, Sampling, and Testing

DEPARTMENT OF DEFENSE STANDARD

MIL-STD-1623 - Fire Performance Requirements and Approved Specifications for Interior Finish Materials and Furnishings (Naval Shipboard Use)

DEPARTMENT OF DEFENSE SPECIFICATIONS

MIL-S-901 - Shock Tests, H.I. (High-Impact); Shipboard Machinery, Equipment and Systems, Requirements for

MIL-PRF-3135 - Deck Covering Underlay Materials

MIL-DTL-24441 - Paint, Epoxy-Polyamide, General Specification for

(Copies of these documents are available online at <http://assist.daps.dla.mil/quicksearch/> or <http://assist.daps.dla.mil> or from the Standardization Document Order Desk, 700 Robbins Avenue, Building 4D, Philadelphia, PA 19111-5094.)

2.2.2 Other Government documents, drawings, and publications. The following other Government documents, drawings, and publications form a part of this document to the extent specified herein. Unless otherwise specified, the issues of these documents are those cited in the solicitation or contract.

BUREAU OF MEDICINE AND SURGERY (BUMED)

BUMED INST 6270.8 - Procedures for Obtaining Health Hazard Assessments (HHAs)

(Copies of this document are available from Bureau of Medicine and Surgery, Department of the Navy, 2300 E Street, NW, Washington DC 20372-5300 or online at <https://bumed.med.navy.mil/>.)

CODE OF FEDERAL REGULATIONS (CFR)

29 CFR 1910.1000 - Air Contaminants

29 CFR 1915.1001, - Polarized Light Microscopy of Asbestos
Appendix K
Method ID-191

29 CFR 1990 - Identification, Classification, and Regulation of Potential Occupational Carcinogens

MIL-PRF-24613A(SH)

- 40 CFR 60, Ch.1, Appendix A-7, Method 24 - Determination of Volatile Matter Content, Water Content, Density, Volume Solids, and Weight Solids of Surface Coatings
- 40 CFR 63 - National Emission Standards for Hazardous Air Pollutants for Source Categories
- 40 CFR 63.782 - National Emission Standards for Shipbuilding and Ship Repair (Surface Coating) Definitions
- 40 CFR 82 - Protection of Stratospheric Ozone
- 40 CFR 261, Appendix II, Method 1311 - Toxicity Characteristic Leaching Procedure (TCLP)
- 40 CFR 302 - Designation, Reportable Quantities, and Notification
- 40 CFR 355 - Emergency Planning and Notification
- 40 CFR 372 - Toxic Chemical Release Reporting: Community Right-to-Know

(Copies of these documents are available from the Superintendent of Documents, U.S. Government Printing Office, Washington DC 20401 or online at www.gpoaccess.gov/index.html.)

NAVAL SEA SYSTEMS COMMAND (NAVSEA)

- S9510-AB-ATM-010 - Nuclear Powered Submarine Atmosphere Control Manual, Volume 1

(Copies of this document are available from the Naval Logistics Library, 5450 Carlisle Pike, Mechanicsburg, PA 17055 or online at <http://nll.ahf.nmci.navy.mil>.)

UNITED STATES ENVIRONMENTAL PROTECTION AGENCY (EPA)

- EPA SW-846 - Test Methods for Evaluating Solid Waste, Physical/Chemical Methods
- EPA 600/4-79-020 - Methods for Chemical Analysis of Water and Wastes

(Copies of these documents are available from the Environmental Protection Agency, Ariel Rios Building, 1200 Pennsylvania Avenue, N.W., Washington DC 20460 or online at www.epa.gov.)

2.3 Non-Government publications. The following documents form a part of this document to the extent specified herein. Unless otherwise specified, the issues of these documents are those cited in the solicitation or contract.

ASTM INTERNATIONAL

- ASTM B117 - Standard Practice for Operating Salt Spray (Fog) Apparatus (DoD adopted)
- ASTM C1028 - Standard Test Method for Determining the Static Coefficient of Friction of Ceramic Tile and Other Like Surfaces by the Horizontal Dynamometer Pull-Meter Method
- ASTM D609 - Standard Practice for Preparation of Cold-Rolled Steel Panels for Testing Paint, Varnish, Conversion Coatings, and Related Coating Products (DoD adopted)
- ASTM D4060 - Standard Test Method for Abrasion Resistance of Organic Coatings by the Taber Abraser (DoD adopted)

MIL-PRF-24613A(SH)

ASTM D3278 - Standard Test Methods for Flash Point of Liquids by Small Scale Closed-Cup Apparatus (DoD adopted)

(Copies of these documents are available from ASTM International, 100 Barr Harbor Dr., PO Box C700, West Conshohocken, PA 19428-2959 or online at www.astm.org.)

The Society for Protective Coatings (SSPC)

SSPC-SP 3 - Power Tool Cleaning (DoD adopted)

SSPC-SP 11 - Power Tool Cleaning To Bare Metal (DoD adopted)

(Copies of these documents are available from the Society for Protective Coatings (SSPC), 40 24th Street, 6th Floor, Pittsburgh, PA 15222 or online at www.sspc.org.)

2.4 Order of precedence. In the event of a conflict between the text of this document and the references cited herein, the text of this document takes precedence. Nothing in this document, however, supersedes applicable laws and regulations unless a specific exemption has been obtained.

3. REQUIREMENTS

3.1 Qualification. The deck covering materials furnished under this specification shall be products that are authorized by the qualifying activity for listing on the applicable qualified products list before contract award (see 4.2 and 6.3).

3.2 Composition. Deck covering materials shall be suitable for application by trowel or broadcast methods to a finished thickness specified by the manufacturer as an overall system, which is intended to be installed either over underlayment in accordance with MIL-PRF-3135, or directly to the primed or unprimed metal substrate. If the product does not require a separate underlayment, it must be able to fair in weld seams, depressions in the deck, and other irregularities to produce an overall smooth and level finish. If the product does not require a separate underlayment, the material shall also be able to be pitched to provide the specified slope to drain in a given space and to form a vertical cove base where the deck meets a bulkhead (a thixotropic additive may be added to the base material to perform these functions). For direct-to-metal products, the system shall include either a separate primer or a bond coat of the system resin material to be applied to the clean and bare metal substrate.

3.2.1 Type I.

3.2.1.1 Class 1. Deck covering materials shall consist of a pre-mixed colored quartz aggregate, clear or colored single component epoxy resin (or separate base and hardener components), and a clear single component epoxy resin (or separate base and hardener components) used as initial seal coat(s). The seal coat(s) may include an aggregate to provide the required slip resistance.

3.2.1.2 Class 2. Deck covering materials shall consist of a clear or solid colored epoxy base resin (or a solid colored base and separate hardener component) to provide the bulk of the functional deck covering system, a solid colored epoxy base resin (or a solid colored base and separate hardener component) to provide the final deck covering color if the bulk of the deck covering system resin is uncolored, color flake chips, and a clear single component epoxy resin (or separate base and hardener components) used as initial seal coat(s). The seal coat(s) may include an aggregate to provide the required slip resistance.

3.2.1.3 Class 3. Deck covering materials shall consist of a pre-mixed marble chip aggregate, a clear or colored single component epoxy resin (or separate base and hardener components), and a clear single component epoxy resin (or separate base and hardener components) used as initial seal coat(s). The seal coat(s) may include an aggregate to provide the required slip resistance.

3.2.1.4 Class 4. Deck covering materials shall consist of multiple single or dual component epoxy resins of different colors (or multiple base materials with separate hardener components of different colors), which shall be mixed together in the field to attain the desired cosmetic appearance, and a clear single component epoxy resin (or separate base and hardener components) used as initial seal coat(s). The seal coat(s) may include an aggregate to provide the required slip resistance.

MIL-PRF-24613A(SH)

3.2.2 Type II.

3.2.2.1 Class 1. Deck covering materials shall consist of a pre-mixed colored quartz aggregate, a clear or colored single component polyurethane or polyurea resin (or separate base and hardener components), and a clear single component polyurethane or polyurea resin (or separate base and hardener components) used as initial seal coat(s). The seal coat(s) may include an aggregate to provide the required slip resistance.

3.2.2.2 Class 2. Deck covering materials shall consist of a colored single component polyurethane or polyurea resin (or separate base and hardener components) to provide the bulk of the functional deck covering system, a solid colored epoxy base resin (or a solid colored base and separate hardener component) to provide the final deck covering color if the bulk of the deck covering system resin is uncolored, color flake chips, and a clear single component polyurethane or polyurea resin (or separate base and hardener components) used as initial seal coat(s). The seal coat(s) may include an aggregate to provide the required slip resistance.

3.2.2.3 Class 3. Deck covering materials shall consist of a pre-mixed marble chip aggregate, a clear or colored single component polyurethane or polyurea resin (or separate base and hardener components), and a clear single component polyurethane or polyurea resin (or separate base and hardener components) used as initial seal coat(s). The seal coat(s) may include an aggregate to provide the required slip resistance.

3.2.2.4 Class 4. Deck covering materials shall consist of multiple single or dual component polyurethane or polyurea resins of different colors (or multiple base materials with separate hardener components of different colors), which shall be mixed together in the field to attain the desired cosmetic appearance, and a clear single component polyurethane or polyurea resin (or separate clear base and hardener components) used as initial seal coat(s). The seal coat(s) may include an aggregate to provide the required slip resistance.

3.2.3 Type III.

3.2.3.1 Class 1. Deck covering materials shall consist of a pre-mixed colored quartz aggregate, and a clear or colored single component epoxy resin (or separate base and hardener components). The mixed product shall be able to pass all of the performance requirements in 3.5 without application of any initial seal coat. However, a clear single component epoxy resin (or separate base and hardener components) shall be specified as the seal coat(s) for use during periodic sanding and resealing maintenance efforts.

3.2.3.2 Class 2. Not applicable. Color flake systems require an initial clear seal/finish coat to be applied to seal the color flakes.

3.2.3.3 Class 3. Deck covering materials shall consist of a pre-mixed marble chip aggregate, and a clear or colored single component epoxy resin (or separate base and hardener components). The mixed product shall be able to pass all of the performance requirements in 3.5 without application of any initial seal coat. However, a clear single component epoxy resin (or separate base and hardener components) shall be specified as the seal coat(s) for use during periodic sanding and resealing maintenance efforts.

3.2.3.4 Class 4. Deck covering materials shall consist of multiple single or dual component epoxy resins of different colors (or multiple base materials with separate hardener components of different colors), that shall be mixed together in the field to attain the desired cosmetic appearance. The product shall be able to pass all of the performance requirements in 3.5 without application of any seal coat. However, a clear single component epoxy resin (or separate base and hardener components) shall be specified as the seal coat(s) for use during periodic sanding and resealing maintenance efforts.

3.2.4 Type IV.

3.2.4.1 Class 1. Deck covering materials shall consist of a pre-mixed colored quartz aggregate, and a clear or colored single component polyurethane or polyurea resin (or separate base and hardener components). The mixed product shall be able to pass all of the performance requirements in 3.5 without application of any initial seal coat. However, a clear single component polyurethane or polyurea resin (or separate base and hardener components) shall be specified as the seal coat(s) for use during periodic sanding and resealing maintenance efforts.

3.2.4.2 Class 2. Not applicable. Color flake systems require an initial clear seal/finish coat to be applied to seal the color flakes.

MIL-PRF-24613A(SH)

3.2.4.3 Class 3. Deck covering materials shall consist of a pre-mixed marble chip aggregate, and a clear or colored single component polyurethane or polyurea resin (or separate base and hardener components). The mixed product shall be able to pass all of the performance requirements in 3.5 without application of any initial seal coat. However, a clear single component polyurethane or polyurea resin (or separate base and hardener components) shall be specified as the seal coat(s) for use during periodic sanding and resealing maintenance efforts.

3.2.4.4 Class 4. Deck covering materials shall consist of multiple single or dual component polyurethane or polyurea resins of different colors (or multiple base materials with separate hardener components of different colors), that shall be mixed together in the field to attain the desired cosmetic appearance. The product shall be able to pass all of the performance requirements in 3.5 without application of any seal coat. However, a clear single component polyurethane or polyurea resin (or separate base and hardener components) shall be specified as the seal coat(s) for use during periodic sanding and resealing maintenance efforts.

3.2.5 Type V.

3.2.5.1 Class 1. Deck covering materials shall consist of a pre-mixed colored quartz aggregate, and a clear or colored single component epoxy resin (or separate base and hardener components). The mixed product shall be able to pass all of the performance requirements in 3.5 without initial or periodic application of any seal coat(s).

3.2.5.2 Class 2. Not applicable. Color flake systems require an initial clear seal/finish coat to be applied to seal the color flakes.

3.2.5.3 Class 3. Deck covering materials shall consist of a pre-mixed marble chip aggregate, and a clear or colored single component epoxy resin (or separate base and hardener components). The mixed product shall be able to pass all of the performance requirements in 3.5 without initial or periodic application of any seal coat(s).

3.2.5.4 Class 4. Deck covering materials shall consist of multiple single or dual component epoxy resins of different colors (or multiple base materials with separate hardener components of different colors), that shall be mixed together in the field to attain the desired cosmetic appearance. The mixed product shall be able to pass all of the performance requirements in 3.5 without initial or periodic application of any seal coat(s).

3.2.6 Type VI.

3.2.6.1 Class 1. Deck covering materials shall consist of a pre-mixed colored quartz aggregate, and a clear or colored single component polyurethane or polyurea resin (or separate base and hardener components). The mixed product shall be able to pass all of the performance requirements in 3.5 without initial or periodic application of any seal coat(s).

3.2.6.2 Class 2. Not applicable. Color flake systems require an initial clear seal/finish coat to be applied to seal the color flakes.

3.2.6.3 Class 3. Deck covering materials shall consist of a pre-mixed marble chip aggregate, and a clear or colored single component polyurethane or polyurea resin (or separate base and hardener components). The mixed product shall be able to pass all of the performance requirements in 3.5 without initial or periodic application of any seal coat(s).

3.2.6.4 Class 4. Deck covering materials shall consist of multiple single or dual component polyurethane or polyurea resins of different colors (or multiple base materials with separate hardener components of different colors), that shall be mixed together in the field to attain the desired cosmetic appearance. The mixed product shall be able to pass all of the performance requirements in 3.5 without initial or periodic application of any seal coat(s).

3.3 Two component resin based systems. The manufacturer is given his choice of ingredients used in the formation of the resins described in this document. For two component resin systems, the allowed proportions for the ratio of resin component to hardener shall be limited to 4:1, 3:1, 2:1, or 1:1 by volume. When mixed and applied in accordance with the manufacturer's instructions, the final deck covering system shall be in accordance with all the performance requirements of 3.5.

MIL-PRF-24613A(SH)

3.4 Application. The deck covering materials shall adhere to the deck, structure or underlayment on which applied without the use of clips or other devices welded to the deck, or other reinforcement not a part of the compound as mixed for application.

3.5 Performance requirements.

3.5.1 Identification characteristics. Values for identification characteristics shall be provided by individual manufacturers for all characteristics indicated by an "X" in Table I below. The values shall be established for each decking system prior to qualification testing. The purpose of these values is to serve as a basis for determining that the material being offered is essentially the same as that which was approved under qualification testing.

TABLE I. Identification characteristics.

| | Aggregate ^{1/} | Bond coat/ primer ^{2/} | | | Primary resin ^{3/} | | | Color coat(s) ^{4/} (if applicable) | | | Seal coat(s) ^{5/} | | |
|---|-------------------------|---------------------------------|---|-------|-----------------------------|---|-------|--|---|-------|----------------------------|---|-------|
| | | Component | | | Component | | | Component | | | Component | | |
| | | A | B | Mixed | A | B | Mixed | A | B | Mixed | A | B | Mixed |
| 1. Chemical nature (percent of each principal constituent (5 percent or more of total) by weight) | X | X | X | | X | X | | X | X | | X | X | |
| 2. Aggregate sizes (sieve analysis) | X | | | | | | | | | | | | |
| 3. Percent aggregate by weight | X | | | | | | X | | | | | | X |
| 4. Percent volatile by weight | | X | X | | X | X | | X | X | | X | X | |
| 5. Percent non-volatile by weight | | X | X | | X | X | | X | X | | X | X | |
| 6. Weight per gallon | | X | X | X | X | X | X | X | X | X | X | X | X |
| 7. Consistency (in Krebs units) | | X | X | X | X | X | X | X | X | X | X | X | X |
| 8. Coverage (in square feet per gallon at minimum specified thickness) | | | | X | | | X | | | X | | | X |
| 9. Dry-to-touch time | | | | | | | | | | | | | |
| at min allowed application temperature | | | | X | | | X | | | X | | | X |
| at max allowed application temperature | | | | X | | | X | | | X | | | X |
| 10. Cure-to-service time | | | | | | | | | | | | | |
| at min allowed application temperature | | | | X | | | X | | | X | | | X |
| at max allowed application temperature | | | | X | | | X | | | X | | | X |

MIL-PRF-24613A(SH)

TABLE I. Identification characteristics - Continued.

NOTES:

- 1/ Aggregate – filler material such as quartz (Class 1) or marble chips (Class 3), or aluminum oxide added to sealer for slip resistance
- 2/ Bond Coat/Primer – any material used to increase adhesion between the primary resin and unpainted bare metal substrates
- 3/ Primary Resin – major resin component of the deck covering system providing the bulk of the strength and other performance characteristics
- 4/ Color Coat(s) – any material used solely to impart color or enhance the appearance of the final deck covering system (other than aggregate)
- 5/ Seal Coat(s) – finish coating intended to fill in void areas, eliminate surface porosity and enhance wear resistance (Types I and II only)

3.5.2 Toxicity. No component of the deck covering system shall have any adverse effect on the health of personnel when used for its intended purpose. The materials used in the deck covering shall have no known carcinogenic or potentially carcinogenic materials identified by OSHA (29 CFR 1990) as regulated carcinogens, or IARC latest monographs, or the latest annual report of the NTP; and shall have no extremely hazardous substances (EHS) or toxic chemicals identified in 29 CFR 1910.1000, 40 CFR 302, 40 CFR 355, and 40 CFR 372, respectively. The use of any Ozone-Depleting Substances (ODS) in any component of the deck covering system under this specification, directly or referenced in any test method, is prohibited. Class I or Class II ozone-depleting chemicals are defined by 40 CFR 82. The manufacturer is responsible for maintaining carcinogenic free, extremely hazardous substance free and toxic chemical free materials. The manufacturer shall not, unless specific material maximum levels are cited herein, allow the addition of any of these prohibited materials to the formulation; and when any of these prohibited materials are/may be present as a result of being present as a trace or impurity in other ingredient(s), the concentration of the prohibited material shall not equal or exceed 0.1 percent by weight of any component of the deck covering system. The material shall undergo an administrative Health Hazard Assessment (HHA) as detailed in BUMED INST 6270.8 by the Navy Environmental Health Center (NEHC) (see 6.6).

3.5.2.1 Asbestos content. The percent by weight of asbestos in the dry deck covering shall be below the detectable threshold.

3.5.2.2 Metal content. The metal content (soluble and total) of any component of the deck covering system shall be less than the values listed in Table II when tested in accordance with 4.5.1. If the test for total metal results in a value less than the soluble metal limit, the soluble metal test need not be conducted. The soluble metal and total metal values shall be reported in Table II results. Soluble metal content shall be reported as milligrams per liter (mg/L). Total metal content shall be reported as percent by weight (%wt) of the dry deck covering film.

TABLE II. Metals content of deck covering components.

| Metal and its compound in each deck covering dry film | Soluble metal, maximum (mg/L) | Total content, maximum (% weight) |
|---|-------------------------------|-----------------------------------|
| Antimony | 15.0 | 0.015 |
| Arsenic | 5.0 | 0.005 |
| Barium (excluding barite) | 100.0 | 0.10 |
| Beryllium | 0.75 | 0.0002 |
| Cadmium | 1.0 | 0.0005 |
| Chromium VI compounds | 1.0 | 0.001 |
| Chromium and chromium III compounds | 560.0 | 0.56 |
| Cobalt* | 50.0 | 0.005 |
| Copper | 25.0 | 0.01 |
| Fluoride salts | 180.0 | 0.18 |
| Lead | 5.0 | 0.005 |
| Mercury | 0.2 | 0.0002 |
| Molybdenum | 350.0 | 0.035 |
| Nickel | 20.0 | 0.02 |
| Selenium | 1.0 | 0.002 |
| Silver | 5.0 | 0.001 |
| Tantalum | 100.0 | 0.100 |

MIL-PRF-24613A(SH)

TABLE II. Metals content of deck covering components - Continued.

| | | |
|---|-------|-------|
| Thallium | 7.0 | 0.007 |
| Tungsten | 100.0 | 0.100 |
| Vanadium | 24.0 | 0.01 |
| Zinc | 250.0 | 0.25 |
| * Total cobalt content may exceed 0.005 %wt (up to 0.2 %wt) only if a cobalt drier is used to effect proper drying. Regardless of whether a cobalt drier is used, soluble cobalt content may not exceed Table I requirements. | | |

3.5.2.3 Hazardous air pollutants (HAPs). The content of the HAPs solvents in any component of the deck covering system shall not exceed the weight percent (%wt) values listed in Table III. Within these limitations and the requirement that the finished deck covering meets all performance requirements of 3.5, solvent selection is the responsibility of the manufacturer. HAP materials are defined by 40 CFR 63.

TABLE III. Hazardous air pollutant solvent content limits.

| Hazardous solvent in mixed deck covering or its components | Maximum, % wt |
|--|---------------|
| Benzene | 0.05 |
| Chlorinated solvent (s), total | 0.05 |
| Solvents containing fluorine as defined by 40 CFR 82 | 0.01 |
| Ethyl benzene | 0.05 |
| Methyl, Ethyl, and Butyl mono-ethers of ethylene glycol or the acetates thereof, total (also known as methyl, ethyl, and butyl cello solves and methyl, ethyl, and butyl cello solve acetates) | 0.05 |
| Methyl ethyl ketone (MEK) | 0.05 |
| Methyl isobutyl ketone (MIBK) | 0.05 |
| Toluene | 0.05 |
| Xylene (all forms), total | 0.1 |

3.5.2.4 Volatile organic content (VOC). The VOC of any deck covering system component shall not exceed 250 grams per liter (2.08 lb/gal). The VOC of Class 4 materials shall be zero grams per liter (0 lb/gal) when measured per 4.5.2.4.

3.5.2.5 Solvents and thinners. Thinning of VOC compliant deck covering is not allowed. The deck covering system components shall be able to be adequately mixed by hand and applied by trowel to the deck at any temperature above 50 °F without the addition of thinning agents.

3.5.3 Flash point. The flash point of the deck covering or any component shall not be less than 38 °C (100 °F).

3.5.4 Weight. After the deck covering has fully cured, the material shall not exceed the following maximum weight limits:

All Types and Grades:

- a. Class 1: 1.75 pounds per square foot (lb/sf) at a thickness of 0.25 inch.
- b. Class 2: 1.5 lbs/sf at a thickness of 0.25 inch.
- c. Class 3: 2.5 lbs/sf at a thickness of 0.25 inch.
- d. Class 4: 1.5 lbs/sf at a thickness of 0.25 inch.

3.5.5 Resistance to impact. The deck covering materials shall not show visible signs of chipping, cracking, or detachment from the steel plate. There shall be not more than 0.0625 inch of permanent indentation for Classes 1, 2, and 3 deck coverings, and not more than 0.03125 inch of permanent indentation for Class 4 products.

MIL-PRF-24613A(SH)

3.5.6 Indentation.

3.5.6.1 Initial indentation. The percent initial indentation of the deck covering material shall be as follows:

| | Type I | Type II | Type III | Type IV | Type V | Type VI |
|---------|---------------|---------------|---------------|---------------|---------------|---------------|
| | Max (percent) | Max (percent) | Max (percent) | Max (percent) | Max (percent) | Max (percent) |
| Class 1 | 5 | 5 | 5 | 5 | 5 | 5 |
| Class 2 | 2 | 2 | 2 | 2 | 2 | 2 |
| Class 3 | 5 | 5 | 5 | 5 | 5 | 5 |
| Class 4 | 10 | 10 | 10 | 10 | 10 | 10 |

3.5.6.2 Residual indentation. The residual indentation of all materials shall not be greater than the following maximum percentages:

| | Type I | Type II | Type III | Type IV | Type V | Type VI |
|---------|---------------|---------------|---------------|---------------|---------------|---------------|
| | Max (percent) | Max (percent) | Max (percent) | Max (percent) | Max (percent) | Max (percent) |
| Class 1 | 1 | 1 | 1 | 1 | 1 | 1 |
| Class 2 | 0.5 | 0.5 | 0.5 | 0.5 | 0.5 | 0.5 |
| Class 3 | 1 | 1 | 1 | 1 | 1 | 1 |
| Class 4 | 0.5 | 0.5 | 0.5 | 0.5 | 0.5 | 0.5 |

3.5.7 Resistance to elevated temperatures. The deck covering materials shall not soften detectably by touch, nor have a measured slippage greater than 0.03125 inch.

3.5.8 Resistance to moisture and temperature changes. The deck covering materials shall show no signs of cracking, separation from the steel plate, or corrosion of the steel beneath the deck covering.

3.5.9 Moisture absorption.

3.5.9.1 Classes 1, 2, and 3. Class 1, 2, and 3 materials shall not absorb greater than 2 percent of moisture by weight.

3.5.9.2 Class 4. Class 4 materials shall not absorb greater than 0.5 percent moisture by weight.

3.5.10 Resistance to chemicals. The deck covering system shall not exceed the following changes in weight and volume.

| Chemical | Weight change (percent maximum) | Volume change (percent maximum) |
|---------------------|------------------------------------|------------------------------------|
| Oil | 3 | 2 |
| JP-5 | 2 | 1 |
| AFFF (50% solution) | 3 | 2 |
| 10% Sulfuric Acid | 2 | 1 |

3.5.11 Resistance to corrosion. The deck covering material shall not soften or become detached; and the surface of the steel beneath the deck covering material shall show no signs of corrosion, capillary action (wicking) or other water penetration under the deck covering.

3.5.12 Fire performance. The deck covering system, including any required primer, underlayment and/or seal coat(s), shall conform to the fire resistance requirements of MIL-STD-1623.

3.5.13 Shock resistance. The deck covering materials shall not show signs of chipping, cracking, or detachment from the steel backing plate.

3.5.14 Adhesive strength.

3.5.14.1 Initial adhesive strength. The initial adhesive strength of the deck covering system (including any required primer and/or underlayment) shall be not less than 250 pounds per square inch (psi).

MIL-PRF-24613A(SH)

3.5.14.2 Adhesive strength after aging. The adhesive strength of the deck covering system (including any required primer and/or underlayment) after aging shall be not less than 70 percent of the initial adhesive strength.

3.5.14.3 Adhesive strength after exposure. The adhesive strength of the deck covering system (including any required primer and/or underlayment) after exposure to moisture and temperature shall be not less than 70 percent of the initial adhesive strength.

3.5.15 Slip resistance. When tested in accordance with ASTM C1028, the deck covering system [including any required seal coat(s)] shall not be less than 0.70 dry and 0.60 wet.

3.5.16 Wear resistance. The material loss of the deck covering system [including any required seal coat(s)] shall not exceed 30 milligrams.

3.5.17 Serviceability. The deck covering system [including any required primer, underlayment and/or seal coat(s)] shall satisfactorily perform its function when examined during and after the minimum shipboard service period specified. Types III, IV, V and VI deck covering systems shall not require any initial seal coat(s), and shall not require any sanding or resealing throughout the specified in-service testing period for each Type.

3.5.18 Off-gassing (Grade A only). The deck covering system [including any required primer and/or bond coat, underlayment and/or seal coat(s)] shall be tested for off-gassing in accordance with the Material Control program of NAVSEA S9510-AB-ATM-010, and shall be certified for and assigned a usage category of either "Limited" or "Permitted" (see 4.5.18 and 6.5).

4. VERIFICATION

4.1 Classification of tests. The inspection requirements specified herein are classified as follows:

- a. Qualification tests (see 4.2).
- b. Conformance tests (see 4.3).

4.2 Qualification tests. Qualification tests shall consist of all of the tests listed in Table IV.

4.2.1 Qualification sample. The qualification sample shall be drawn from a production batch and shall consist of enough component materials (e.g., aggregate, base, hardener and sealer for a two-component Type I, Class 3 system) to create 2 gallons (~8 liters) of the final mixed deck covering.

4.2.2 Formulation changes. Any change in basic ingredients or manufacturing processes (other than minor changes in pigment concentrations strictly to adjust final deck covering system color) that would affect compliance with this specification must be reported to both the contracting activity and NAVSEA. The Government reserves the right to require that all tests specified in this specification be re-performed on a production batch of the deck covering produced under the new formulation or process before any shipment is accepted. Any formulation change not disclosed to NAVSEA will result in immediate disqualification of the product.

4.3 Conformance tests. Conformance tests shall consist of specific tests identified in Table IV.

4.3.1 Lot. All unmixed material of the same type, but not more than a daily production run, offered for delivery at one time, shall be considered a lot for purposes of conformance testing. The addition of any substance to a batch shall constitute a new lot and full conformance testing is required.

4.3.2 Sampling for conformance testing. The contractor shall select a production sample of each component of the deck covering system (e.g. resin base, hardener, aggregate, and seal coat for a Type I, Class 3 system) sufficiently large enough to permit the performance of all conformance tests. If testing cannot be performed at the manufacturer's facilities, two representative packaged samples shall be forwarded to an unaffiliated third party laboratory for verification tests. If the deck covering material is to be applied to sample panels at the vendor's facility and forwarded to an external laboratory for testing, preparation of the panels and application of the deck covering system must be observed by a representative from the Defense Contracts Management Agency (DCMA).

MIL-PRF-24613A(SH)

4.3.3 Fire performance testing. A running total of material produced for all batches shall be kept. Manufacturers' records shall be used to determine quantities of material delivered. The fire performance tests of MIL-STD-1623 (see 3.5.12 and 4.5.12) shall be conducted as part of the lot acceptance tests once for every 50,000 pounds of unmixed material produced for delivery under one or more contracts or orders. If any sample fails any fire performance test, the tests of 4.5.12 shall be run on every subsequent batch until four successive batches have passed all required fire performance tests.

4.3.4 Small lots. Conformance tests shall not be required on any delivery of less than 2,000 pounds of unmixed material. However, deliveries of such small quantities that have not been tested shall be so identified in the manufacturer's records. Once the accumulated total of such untested deliveries reaches 2,000 pounds, sample material shall be selected and subjected to the required conformance tests identified in Table IV.

TABLE IV. Tests.

| Item | Qualification testing required | Conformance testing required | Requirement paragraph | Test method paragraph |
|--|--------------------------------|------------------------------|-----------------------|-----------------------|
| Identification characteristics | Yes | No | 3.5.1 | 4.5.1 |
| Toxicity | Yes | No | 3.5.2 | 4.5.2 |
| Asbestos content | Yes | No | 3.5.2.1 | 4.5.2.1 |
| Total and soluble metal content | Yes | No | 3.5.2.2 | 4.5.2.2 |
| Hazardous air pollutant (HAP) content | Yes | No | 3.5.2.3 | 4.5.2.3 |
| Volatile organic content (VOC) | Yes | Yes | 3.5.2.4 | 4.5.2.4 |
| Flash point | Yes | Yes | 3.5.3 | 4.5.3 |
| Weight | Yes | Yes | 3.5.4 | 4.5.4 |
| Resistance to impact | Yes | Yes | 3.5.5 | 4.5.5 |
| Initial indentation | Yes | Yes | 3.5.6.1 | 4.5.6.1 |
| Residual indentation | Yes | Yes | 3.5.6.2 | 4.5.6.2 |
| Resistance to elevated temperatures | Yes | No | 3.5.7 | 4.5.7 |
| Resistance to moisture and temperature changes | Yes | No | 3.5.8 | 4.5.8 |
| Moisture absorption | Yes | Yes | 3.5.9 | 4.5.9 |
| Resistance to chemicals | Yes | No | 3.5.10 | 4.5.10 |
| Resistance to corrosion | Yes | No | 3.5.11 | 4.5.11 |
| Fire performance | Yes | Yes (see 4.3.3) | 3.5.12 | 4.5.12 |
| Shock resistance | Yes | No | 3.5.13 | 4.5.13 |
| Initial adhesive strength | Yes | No | 3.5.14.1 | 4.5.14.1 |
| Adhesive strength after aging | Yes | No | 3.5.14.2 | 4.5.14.2 |
| Adhesive strength after exposure | Yes | No | 3.5.14.3 | 4.5.14.3 |
| Slip resistance | Yes | Yes | 3.5.15 | 4.5.15 |
| Wear resistance | Yes | No | 3.5.16 | 4.5.16 |
| Serviceability | Yes | No | 3.5.17 | 4.5.17 |
| Off-gassing (Grade A only) | Yes | No | 3.5.18 | 4.5.18 |

4.3.5 Noncompliance. If a sample fails to pass its conformance inspections, the lot shall be rejected and the manufacturer shall notify the cognizant inspection activity of such failure and take corrective action on the materials or processes, or both, as warranted. Acceptance and shipment of the product shall be discontinued until corrective action, suitable to the inspection activity, has been taken. After the corrective action has been taken, conformance inspections shall be repeated on the new lot. In the event of failure after re-inspection, information concerning the failure shall be furnished to the cognizant inspection activity.

MIL-PRF-24613A(SH)

4.4 Inspection conditions. Unless otherwise specified in 4.5, all tests shall be performed in accordance with the test conditions specified in Section 9, Routine and Referee Testing Conditions, of FED-STD-141. The term referee conditions shall mean a temperature of 23 ± 1 °C (73 ± 2 °F) and a relative humidity of 50 ± 4 percent. All test specimens shall be cured to service in accordance with manufacturer's instructions before testing unless otherwise specified (see 4.5).

4.4.1 Test panels and surface preparation. Unless otherwise specified in 4.5, test panels shall be nominal 150 millimeters by 150 millimeters by 3 millimeters (6 inches by 6 inches by 0.125 inch) plate aluminum or 150 millimeters by 150 millimeters by 3 millimeters (6 inches by 6 inches by 0.125 inch) cold rolled steel. Test panels shall be preconditioned by exposing the bare metal panels to a salt fog spray for 100 hours in accordance with ASTM B117. Test panels shall then be wiped and degreased in accordance with Methods B, C, or D of ASTM D609. The degreased test panels shall be mechanically cleaned in accordance with SSPC-SP 3 on both sides. For direct-to-metal deck covering systems (that don't require a separate primer or underlayment), the panels shall remain unprimed prior to application of the deck covering system. For deck covering systems requiring an anti-corrosive primer, the panels shall be primed with the primer or bond coat included by the manufacturer as part of the deck covering system, or with a primer conforming to MIL-DTL-24441 if no specific primer is identified by the manufacturer. For products that require installation over underlayment conforming to MIL-PRF-3135, Type III, Class 2 shall be applied to the panel to a thickness of 0.125 inch and allowed to cure to service per manufacturer's instructions.

4.5 Tests.

4.5.1 Identification characteristics. The manufacturer shall provide a report providing all of the identification characteristics required by Table I.

4.5.2 Toxicity. To determine conformance with the requirements of 3.5.2, the material shall be evaluated by the Navy Environmental Health Center (NEHC) (see 6.6).

4.5.2.1 Asbestos content. Asbestos content shall be determined on a dry film of the deck covering in accordance with 29 CFR 1915.1001, Appendix K, and the results shall be recorded as a percent by weight of the dry deck covering film.

4.5.2.2 Soluble and total metal content. Soluble and total metal content, except tantalum and tungsten, shall be determined on a dry film of the deck covering system in accordance with the 40 CFR 261, Appendix II, Method 1311, and the appropriate test listed in Tables V and VI. Tantalum and tungsten soluble metal content and total metal content shall be analyzed as specified in 4.5.2.2.1.

TABLE V. Test methods for evaluating solid waste physical/chemical methods, EPA SW-846.

| Metal/material | Digestion test method |
|----------------------------------|-----------------------|
| All metals, except chromium (VI) | 3050 |
| Chromium (VI) | 3060 |
| Antimony | 7040 or 7041 |
| Arsenic | 7060 or 7061 |
| Barium | 7080 or 7081 |
| Cadmium | 7131 |
| Total chromium | 7190 |
| Chromium (VI) | 7195, 7196, or 7197 |
| Lead | 7421 |
| Mercury | 7470 or 7471 |
| Nickel | 7520 or 7521 |
| Selenium | 7740 or 7741 |
| Silver | 7760 or 7761 |

MIL-PRF-24613A(SH)

TABLE VI. Methods for chemical analysis of water and waste, EPA 600/4-79-020.

| Metal/material | Test method |
|----------------|-----------------------|
| Beryllium | 210.1 or 210.2 |
| Cobalt | 219.1 or 219.2 |
| Copper | 220.1 or 220.2 |
| Fluoride | 340.1, 340.2 or 340.3 |
| Molybdenum | 246.1 or 246.2 |
| Thallium | 279.1 or 279.2 |
| Vanadium | 286.1 or 286.2 |
| Zinc | 289.1 or 289.2 |

4.5.2.2.1 Tantalum and tungsten content. The tantalum and tungsten content of the deck covering shall be determined using any appropriate spectroscopy test method. The tests shall be conducted in accordance with the equipment manufacturer's directions for the use of the instrument. The deck covering manufacturer is responsible for establishing data justifying the test method choice and analytical accuracy.

4.5.2.3 Hazardous air pollutant (HAP) content. Formulation data shall be used by manufacturers in lieu of testing to demonstrate compliance with hazardous air pollutant requirements of this specification. The manufacturer's formulation data must have a consistent and quantitatively known relationship to the testing required. Calculation of individual HAP contents can be based on either manufacturer evaluation of batches or supplier data for raw materials used in the product. The deck covering manufacturer must provide, for each individual HAP, a formulation value that will not be exceeded if a sample from any quality control approved production batch of the deck covering is evaluated in accordance with this paragraph.

4.5.2.4 Volatile organic content (VOC). VOC for each batch (as described in 40 CFR 63.782) of any component of the deck covering system (excluding aggregate) shall be determined in accordance with 40 CFR 60 Ch.1, Appendix A, Method 24, allowing the sample to reside at 22 ± 1 °C (72 ± 2 °F) for 24 hours prior to conducting the analysis. No oven heating is allowed.

4.5.3 Flash point. The flash point of each component shall be determined in accordance with ASTM D3278.

4.5.4 Weight. Three panels shall be prepared in accordance with 4.4.1, with the exception that no underlayment shall be applied to the panels. These panels shall then be weighed, and the uncovered weight of each panel recorded to the nearest 0.1 pound. The deck covering system shall then be applied to a total thickness of ¼ inches (not including the plate and primer thicknesses). When the material has fully cured at referee conditions in accordance with manufacturer's instructions, the three test specimens shall then be weighed to the nearest 0.1 pound. The uncovered weight of each panel recorded prior to application of the deck covering system shall then be subtracted from the weight of that same plate with the cured complete system. These weights shall then be multiplied by a factor of four to give pounds per square foot at 0.25-inch thickness for each panel. The results from the three test panels shall then be averaged, and the final average pounds per square foot at ¼-inch thickness of the material recorded.

MIL-PRF-24613A(SH)

4.5.5 Resistance to impact. Two panels shall be prepared in accordance with 4.4.1. The deck covering system shall then be applied to both panels to the maximum thickness allowed by the manufacturer's instructions, or 0.25 inch, whichever is less (excluding the thickness of the plate, primer and any required underlayment applied in 4.4.1), and allowed to fully cure at referee conditions in accordance with manufacturer's instructions. Measurements of the thickness of the material shall be made at the geometric center of the sample and at nine other random points, to ensure the deck covering thickness at all points is uniform to within plus or minus 0.03125 inch. The first specimen shall be firmly mounted on a solid horizontal base. A 2-pound steel ball shall be dropped vertically from a height of eight feet onto the deck covering, such that the impact will be at the center of the specimen. The specimen shall be subjected to two impacts of the ball. The deck covering shall then be visually examined for chipping, cracking or delamination from the steel plate. The thickness of the deck covering at the point of impact of both balls shall then be measured. The residual indentation shall then be measured by calculating the difference between the thickness of the deck covering at the center of the sample before impact and the thickness of the deck covering at the center of the sample after impact. This procedure shall then be repeated on the second panel, and the two residual indentation results averaged and recorded.

4.5.6 Indentation. Four panels shall be prepared in accordance with 4.4.1. The deck covering system shall be applied to each panel to the minimum thickness allowed by the manufacturer (excluding the thickness of the plate, primer and any required underlayment applied in 4.4.1). Two panels shall be allowed to cure for 96 hours at referee conditions. Two panels shall only be allowed to cure for 24 hours at referee conditions. The thickness of the deck covering shall be measured in three locations not less than 1.5 inches from any edge of the specimen, and not less than 2.5 inches from the center of an adjoining measurement. The thickness of the deck covering at each of these three locations shall be measured with a micrometer dial gage with a 4-ounce weight and a 0.25-inch-diameter flat foot, to an accuracy of ± 0.03125 inch. A permanent marker shall be used to mark these three locations. Each panel shall be mounted on a plate designed to support both the panel and a 2,000 pound load without allowing the specimen to slide. The specimen mounting plates selected for the indentation tests shall be checked for flatness before being used. Indentations shall be made on the deck covering material at each of these three locations by placing a load of 2,000 pounds over a flat faced, circular indenter, for 30 minutes at each spot. The indenter's flat face shall have an area of 1 square inch and its perimeter shall be rounded to a radius of 0.015625 inch. Care shall be taken to ensure that specimen is maintained parallel and level to the ground throughout the 30 minute indentation period.

4.5.6.1 Initial indentation. Immediately after the weight is lifted from each spot on each panel, the thickness of the deck covering shall be measured at that spot. The thickness of the deck covering immediately after the weight is removed shall then be divided by the thickness of the deck covering measured initially at that location, and the result multiplied by 100 percent. The initial indentation percentages for each of the three spots on a given panel shall then be averaged, and the average initial indentation percentage recorded for that panel. Follow the same procedure for the remaining three panels.

4.5.6.2 Residual indentation. Two hours after the weight is lifted from each spot on each panel, the thickness of the deck covering shall be measured again at that spot. The thickness of the deck covering two hours after removal of the weight shall then be divided by the thickness of the deck covering measured initially (before the weight was applied) at that location, and the result multiplied by 100 percent. The residual indentation percentages for each of the three spots on a given panel shall then be averaged, and the average residual indentation percentage recorded for that panel. Follow the same procedure for the remaining three panels.

MIL-PRF-24613A(SH)

4.5.7 Resistance to elevated temperatures. Two plates shall be prepared in accordance with 4.4.1, with the exception that the plates shall be 6 by 2 by 0.125 inches. The deck covering shall be applied to each plate at the manufacturer's maximum allowed thickness, or 0.25 inch, whichever is less (excluding the thickness of the plate, primer and any required underlayment applied in 4.4.1), and allowed to cure to service per manufacturer's instructions. The deck covering shall then be scribed with a line parallel to and approximately 1 inch from one of the 2-inch edges. The edge closest to the scribe shall be identified as the "reference edge." The distance between this line and the "reference edge" of each steel plate shall be measured to the nearest 0.01 inch. The specimens shall then be suspended vertically from the end opposite the "reference edge" in an oven maintained at a constant temperature of 160 ± 2 °F for 5 hours. At the end of this two hour period, the deck covering material shall be examined by touch (the inspector should wear gloves) immediately after the specimens have been removed from the oven, to determine whether the material has softened under the action of heat. The specimens shall then be allowed to cool to room temperature. When the specimens have cooled to room temperature, the distance between the "reference edge" and the scribe on each plate shall be measured again. The difference in the distance between the scribe and the "reference edge" before and after heating shall be calculated for each plate, and the results averaged and recorded as the deck covering slippage.

4.5.8 Resistance to moisture and temperature changes. Two panels shall be prepared in accordance with 4.4.1, with the exception that the plates shall be 6 inches by 2 inches by 0.125 inch. The deck covering shall be applied to each plate at the manufacturer's minimum allowed thickness (excluding the thickness of the plate, primer and any required underlayment installed in 4.4.1), and allowed to cure to service per manufacturer's instructions. Both panels shall then be immersed in a solution of 4 percent sodium chloride in water, under a pressure of 8 psi, for 48 hours. Immediately after immersion, the specimens shall be subjected to two complete cycles of alternate exposure to a temperature of 0 ± 5 °F for 24 hours, followed by a temperature of 120 ± 5 °F for 24 hours. The deck covering system shall then be visually examined for evidence of cracking or other failure. A portion of the deck covering system shall then be carefully removed from the plate to observe any signs of rusting or corrosion beneath the deck covering.

4.5.9 Moisture absorption. Three 2- by 2- by 0.125-inch panels of cold rolled steel shall be prepared by submerging the panels in oil, and then removing them without cleaning or wiping the oil from the surface. The deck covering shall be applied to the panels at 0.25-inch thickness (excluding the thickness of the plates) and allowed to cure to service at referee conditions in accordance with manufacturer's instructions; however, the deck covering shall not be allowed to adhere to the oiled plates. Each fully cured specimen of deck covering (after being removed from the steel backing plate) shall then be completely submerged in tap water at room temperature, then immediately removed. All surfaces shall be lightly wiped with a paper towel to remove excess water from the surface of the deck covering, and then immediately weighed to the nearest 0.1 ounce. After this initial weight has been recorded, the specimens shall be fully immersed again in room temperature tap water for a period of 24 hours. After 24 hours, the specimens shall be removed, lightly wiped with paper towels to remove excess water from the surface, and again weighed to the nearest 0.1 ounce. The percent gain in moisture for each sample shall then be calculated by dividing the weight of the sample after the 24 hour exposure period by the weight of that sample after the initial dipping in tap water, and multiplying by 100 percent. The percent moisture absorption shall then be averaged for all three samples, and the result recorded.

MIL-PRF-24613A(SH)

4.5.10 Resistance to chemicals. Eight panels shall be prepared for the moisture absorption test in 4.5.8. Two deck covering specimens (after being removed from the steel backing plate) shall be completely immersed in SAE 10W-40 oil, then removed and rinsed in room temperature tap water. Each specimen shall then be fully immersed in room temperature tap water in a separate large glass beaker with graduated volume markings on the side. The initial volume of the water and immersed sample shall be recorded (note: if the sample floats, disregard all volume measurements and calculations). The specimens shall then be carefully taken out of the beaker, minimizing the amount of water removed from the beaker along with the sample, and lightly wiped on all surfaces with a paper towel to remove excess water from the surface. The specimens shall then be immediately weighed to the nearest 0.1 ounce. After the initial weights have been recorded, the specimens shall then be immersed for 24 hours in the same oil. After the 24-hour exposure period, the specimens shall be removed, rinsed clean with room temperature tap water, and then once again fully immersed in the same beaker of room temperature tap water. The volume of the water with the immersed specimen in the beaker shall then be recorded, and the specimen removed and lightly wiped. The specimens shall then be immediately weighed again, and the post-exposure weights recorded. The percent change in weight shall then be calculated by dividing the weight of each sample after the 24-hour exposure period by the weight of each specimen before exposure, and multiplying by 100 percent. The results from the two specimens shall be averaged, and the average percent weight change recorded. The percent change in volume shall be calculated by dividing the volume of water and specimen recorded in the beaker after the 24-hour exposure period by the volume of water and specimen in the beaker recorded prior to exposure, and the result multiplied by 100 percent. The results of the two specimens shall be averaged, and the average percent change in volume recorded. This procedure shall be repeated on the next set of two specimens, with the exception that the panels shall be immersed in JP-5 jet fuel instead of SAE 10W-40 oil. The procedure shall then be repeated on the next set of two specimens, immersing the specimens in a 50 percent solution of aqueous film forming foam (AFFF) instead of JP-5. The procedure shall then be repeated on the final set of two specimens by immersing them in a 10 percent sulfuric acid solution instead of a 50 percent AFFF solution. The average percent change in weight and percent change in volume after immersion in each fluid shall then be recorded.

4.5.11 Resistance to corrosion. Two panels shall be prepared in accordance with 4.4.1, with the exception that the panels shall be cold rolled steel, 6 inches by 2 inches by 0.125 inch, and the pre-conditioned surfaces shall be cleaned of all visual rust in accordance with SSPC-SP 11. The deck covering shall be applied to the panels at the manufacturer's minimum allowed thickness (excluding the thickness of the plate, primer and any required underlayment applied in 4.4.1) and allowed to cure to service in accordance with manufacturer's instructions. The panels shall then be immersed in a 10 percent sodium chloride solution for 15 days, during which time a continuous stream of air shall be passed through the solution, in order to promote corrosion. Immediately after removal from this solution, the specimens shall be examined by touch to determine whether the material has softened or detached from the steel backing plates. A portion of the deck covering system shall then be removed carefully from the steel plates, and the substrate visually examined for signs of rusting or corrosion of the steel plate beneath the deck covering.

4.5.12 Fire performance. The manufacturer shall submit a report showing the product passes all testing required by MIL-STD-1623 for deck coverings, including the actual results of that testing, as witnessed and certified by the Defense Contracts Management Agency (DCMA).

MIL-PRF-24613A(SH)

4.5.13 Shock resistance. Three panels shall be prepared in accordance with 4.4.1, with the exception that the plates shall be cold rolled steel, 8 inches by 8 inches by 0.125 inch. The deck covering shall then be applied to the maximum thickness allowed by the manufacturer, or 0.25 inch, whichever is less (excluding the thickness of the plate, primer and any required underlayment applied in 4.4.1) to each panel, covering a 6- by 6-inch area centered on the plate, by means of wooden templates such that a 1-inch wide portion of the steel plate is exposed along the entire periphery of the specimen. The deck covering shall be allowed to cure to service at referee conditions in accordance with manufacturer's instructions. Each specimen shall then be subjected to high-impact lightweight shock testing in a testing machine conforming to MIL-S-901. Each specimen shall be centrally secured to the test plate of the testing machine by eight 0.25-inch diameter machine screws, equally located along the periphery of the specimen plate, 0.5 inch away from the edge of the specimen steel plate. Each specimen shall then be subjected to a series of shocks consisting of consecutive, increasing impacts of 100, 200, 400, 700, 1,000, 1,400, and 2,000 foot-pounds (ft/lb) to provide approximately uniform increase of striking velocity. The 2,000-ft/lb blow shall then be immediately followed by a second 2,000-ft/lb blow. The deck covering shall then be visually examined for chipping, cracking, or detachment from the steel backing plate. Class 4 deck covering materials shall be further subjected to two additional consecutive 2,200 ft/lb blows before visually inspecting the panels for chipping, cracking or detachment from the steel backing plate.

4.5.14 Adhesive strength. Eighteen panels shall be prepared in accordance with 4.4.1, with the exception that the panels shall be 6 inches by 2 inches by 0.125 inch. Deck covering shall be applied to the panels to a total thickness of 0.25 inch (excluding the thickness of the plate and primer, but including the thickness of any required underlayment installed in 4.4.1) in such a way that it only covers 2 inches square on each specimen. By using a wooden template, the deck covering system shall be applied such that 1 inch of the steel plate is exposed at one end, and 3 inches exposed at the opposite end. Specimens shall be tested by measuring the load (in pounds per square inch) required to shear the 2-inch square area of deck covering from the steel backing plate by means of a shear test jig similar to that shown in Figure 1 below. All specimens shall be tested by compression loading at a rate of 0.25 inch per minute.

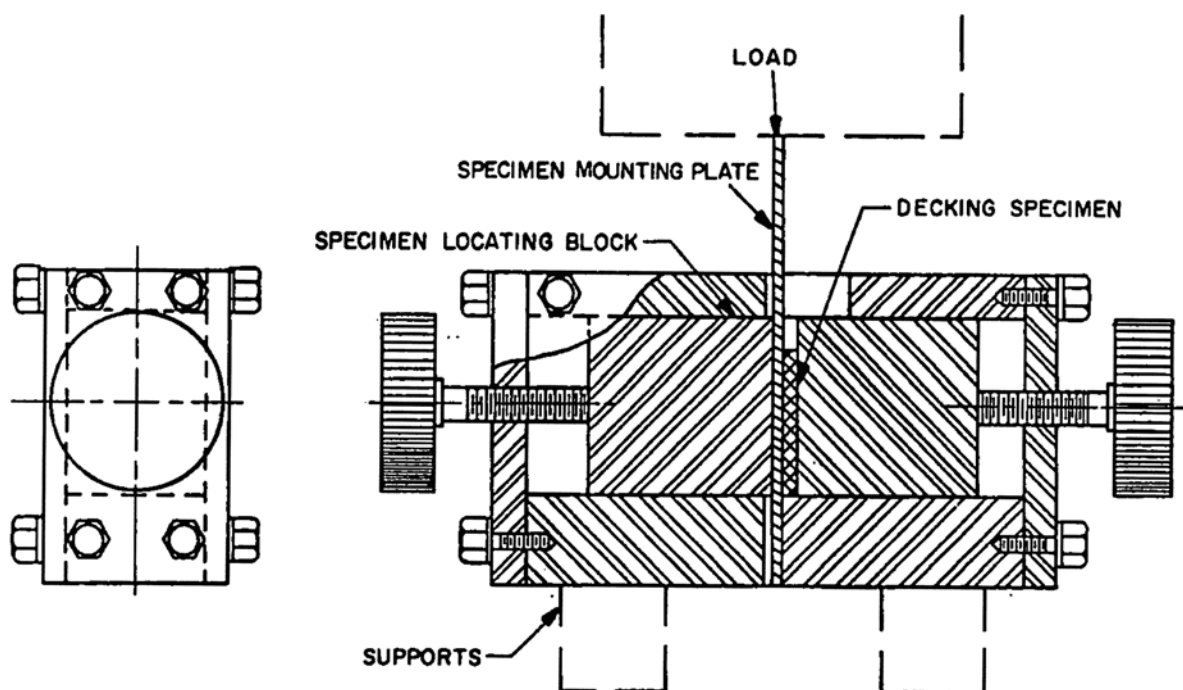

FIGURE 1. Shear test jig for hard-setting deck covering materials.

MIL-PRF-24613A(SH)

4.5.14.1 Initial adhesive strength. The shear force required to separate the deck covering from the steel backing plate for the first six panels shall be determined. The measured adhesive strength shall be averaged for all six specimens, and the average initial adhesive strength recorded.

4.5.14.2 Adhesive strength after aging. The next six specimens shall be aged in an oxygen bomb for 96 hours under a pressure of 300 psi and temperature of 158 ± 2 °F. The shear force required to separate the deck covering from the steel backing plate for all six panels shall be determined. The measured adhesive strength for all six specimens shall be averaged, and the average adhesive strength after aging recorded.

4.5.14.3 Adhesive strength after exposure. The remaining six specimens shall be exposed to one complete moisture and temperature cycle as defined in 4.5.7. The shear force required to separate the deck covering from the steel backing plate for all six panels shall be determined. The measured adhesive strength for all six specimens shall be averaged, and the average adhesive strength after exposure recorded.

4.5.15 Slip resistance. Three panels shall be prepared per 4.4.1. The deck covering system [including any required seal coat(s)] shall be applied to the manufacturer's minimum allowed thickness (excluding the thickness of the plate, primer and any required underlayment applied in 4.4.1). The dry and wet slip resistance of the panels shall then be measured in accordance with ASTM C1028.

4.5.16 Wear resistance. Three panels shall be prepared per 4.4.1. The deck covering system [including any required seal coat(s)] shall be applied to the manufacturer's minimum allowed thickness (excluding the thickness of the plate, primer and any required underlayment applied in 4.4.1). Wear resistance shall then be measured in accordance with ASTM D4060, using a CS 17 wheel, 1000 cycles and a 1 kg load.

4.5.17 Serviceability. The deck covering system [including any required primer, underlayment and/or seal coat(s)] shall be applied in NAVSEA designated or approved representative areas aboard a U.S. Naval vessel for a minimum service period of six months. Type V and VI deck covering systems shall be evaluated for a minimum in-service period of five years.

4.5.18 Off-gassing (Grade A only). The deck covering system [including any required primer, underlayment and/or seal coat(s)] shall be tested in accordance with the Material Control program of NAVSEA S9510-AB-ATM-010 by a Government approved testing facility. The results shall be submitted to the Government for evaluation and approval for use (see 3.5.18 and 6.5).

5. PACKAGING

5.1 Packaging. For acquisition purposes, the packaging requirements shall be as specified in the contract or order (see 6.2). When packaging of materiel is to be performed by DoD or in-house contractor personnel, these personnel need to contact the responsible packaging activity to ascertain packaging requirements. Packaging requirements are maintained by the Inventory Control Point's packaging activities within the Military Service or Defense Agency, or within the military service's system commands. Packaging data retrieval is available from the managing Military Department's or Defense Agency's automated packaging files, CD-ROM products, or by contacting the responsible packaging activity.

6. NOTES

(This section contains information of a general or explanatory nature that may be helpful, but is not mandatory.)

6.1 Intended use. The deck covering material covered by this specification is intended to provide low maintenance, highly durable deck coverings that will provide an acceptable aesthetic appearance and superior corrosion protection of metal substrates throughout the expected minimum service life of ten years.

MIL-PRF-24613A(SH)

6.2 Acquisition requirements. Acquisition documents should specify the following:

- a. Title, number, and date of the specification.
- b. Type, class, and grade required (see 1.2).
- c. The specific issue of individual documents referenced (see 2.2.1, 2.2.2, and 2.3).
- d. Packaging requirements (see 5.1).
- e. Whether MSDS and ASTM F718 data sheets are required with each shipment (see 6.4).
- f. Batch VOC certification (see 6.7).

6.3 Qualification. With respect to products requiring qualification, awards will be made only for products which are, at the time of award of contract, qualified for inclusion in Qualified Products List QPL No. 24613, whether or not such products have actually been so listed by that date. The attention of the contractors is called to these requirements, and manufacturers are urged to arrange to have the products that they propose to offer to the Federal Government tested for qualification in order that they may be eligible to be awarded contracts or orders for the products covered by this specification. Information pertaining to qualification of products may be obtained from Commander, Naval Sea Systems Command, ATTN: SEA 05M3, 1333 Isaac Hull Avenue, SE, Stop 5160, Washington Navy Yard DC 20376-5160 or emailed to CommandStandards@navy.mil.

6.4 Material safety data sheets. When required, contracting officers will identify those activities requiring companies of completed Material Safety Data Sheets prepared in accordance with FED-STD-313. In order to obtain the MSDS, FAR clause 52.223-3 must be in the contract.

6.5 Off-gassing. Grade A deck covering systems to be installed in submarines are to be controlled to prevent off-gassing, which contaminates the atmosphere and results in health hazards to personnel or deleterious effects on machinery. These controls are accomplished through the Submarine Material Control Program, which is described in the Material Control Program of NAVSEA S9510-AB-ATM-010. Under the Submarine Material Control Program, all materials considered for use on submarines require certification and assignment of a usage category. Under the certification process, candidate materials are selected by Navy activities or contractors, and a request for certification is submitted to Commander, Naval Sea Systems Command, SEA 05Z42, 1333 Isaac Hull Ave., SE, Stop 5122, Washington Navy Yard DC 20376-5122. The certification request is accompanied by detailed information, including descriptions of the material, method of application, usage, and storage. A chemical analysis is conducted, which is normally accomplished through off-gas testing. The off-gas test is required to be conducted in a Government approved laboratory designated by the preparing activity. Information pertaining to this test requirement may be obtained from this same address. Based on the chemical analysis results, a usage category is assigned to the material defining whether, and to what extent, the material may be used on submarines.

6.6 Toxicity evaluation. BUMED INST 6270.8 contains instructions for how an administrative Health Hazard Assessment (HHA) is to be conducted. The Navy Environmental Health Center (NEHC) requires sufficient information to permit an HHA of the product. Any questions concerning toxicity, information required to conduct an HHA, and requests for HHAs should be addressed to the Commanding Officer, Navy Environmental Health Center, ATTN: Hazardous Materials Department, Industrial Hygiene Directorate, 620 John Paul Jones Circle, Suite 1100, Portsmouth, VA 20378-2103. Upon receipt of the HHA, a copy should be provided to Commander, Naval Sea Systems Command, SEA 05M1, 1333 Isaac Hull Ave., SE, Stop 5133, Washington Navy Yard DC 20376-5133.

6.7 Volatile content. Contracting officers will require the contractor to provide the Government with a written Volatile Organic Content (VOC) certification, as described in 40 CFR 63.785(a)(2), for each batch of product from which any quantity of the deck covering is supplied to the Government under the contract. The Government reserves the right to reject as defective any deck covering materials for which the VOC certification have not been provided.

MIL-PRF-24613A(SH)

6.8 Suggested packaging requirements. Suggested packaging markings are contained in Table VII.

TABLE VII. Suggested marking.

| Marking type | Recommended marking |
|---|---|
| Bar codes | Marking should include bar codes |
| Hazardous warnings | a. Labels should be in accordance with 29 CFR Parts 1910, 1915, 1917, 1918, 1926, and 1928. |
| | b. All individual containers of latex rubber, resin or hardener should have the following marking: “CAUTION: This product contains volatile solvents, with probable hazardous vapors. Use with adequate ventilation. Avoid prolonged breathing of vapors or spray mists. The solvents are highly flammable, avoid open flame and smoking.” |
| | c. Each component container, shipping container, and palletized load should be marked with the appropriate hazardous symbol in accordance with FED-STD-313. |
| Volatile organic content (VOC) | “Contains (insert VOC content) grams per liter (insert VOC content in lb/gal) of volatile organic content per 40 CFR 60, Appendix A (EPA) Method 24. Addition of any solvents or thinners is not allowed.” |
| OSHA Hazard Communication Act and FED-STD-313 | Markings should include all information necessary to comply with OSHA Hazard Communication Act and FED-STD-313. |
| Mixing and use instructions | Labels should include this warning: “Refer to manufacturer’s written mixing and application instructions prior to use.” Two-component resin based products should also contain this warning on each can of resin and hardener: “CAUTION: This is one component of a two component system which WILL NOT HARDEN unless both components are properly mixed together in accordance with manufacturer’s instructions.” Directions should include mixing, application equipment directions, limitations on thinning, temperature range for use and surface preparation recommendations. Directions should refer user to manufacturer’s data sheets or MSDS sheets for information. |
| Hazardous air pollutants | “Contains (insert HAP content here in g/L and lb/gal) solids (nonvolatiles) per 40 CFR 63.” |
| Shelf Life | Labels should include the product’s shelf life expiration date. |

6.9 Changes from previous issue. Marginal notations are not used in this revision to identify changes with respect to the previous issue due to the extent of the changes.

6.10 Subject term (key word) listing.

Broadcast quartz
 Color flake
 Cosmetic
 Deck covering
 Marble chip
 Resin terrazzo

MIL-PRF-24613A(SH)

Preparing Activity:
Navy – SH
(Project 5610-2006-003)

NOTE: The activities listed above were interested in this document as of the date of this document. Since organizations and responsibilities can change, you should verify the currency of the information above using the ASSIST Online database at <http://assist.daps.dla.mil>.